

SA85 GNSS Antenna

GNSS Geodetic
Antenna



SA85 TECHNICAL FEATURES

GNSS Geodetic Antenna

SA85 is a compact GNSS geodetic antenna, perfect as a rover antenna, but with adequate performance for CORS installation and monitoring applications. It can track all constellations, GPS, GLONASS, GALILEO, BEIDOU, QZSS, IRNSS and receives L-band correction. The SA85 has good phase center stability, effectively improves measurement accuracy and provides excellent positioning solutions. It is compatible with all GNSS geodetic receivers on the market and can be used for all static and kinematic measurement applications. The ability to receive low-elevation signals with high gain enables it to provide accurate and reliable position even under difficult conditions.

The SA85 is lightweight, with only 450g it is one of the lightest in its class, so it can be easily installed on a pole to be connected to an external GNSS.

PERFORMANCE

Satellite signals tracked	GPS: L1, L2, L5
	GLONASS: L1, L2, L3
	BEIDOU: B1, B2, B3
	GALILEO: E1, E5a, E5b, E6
	QZSS: L1, L2, L5, L6
	IRNSS: L5
	SBAS: L1, L5
Type	Geodetic Antenna
Phase Center Stability	± 2 mm
Nominal Impedance	50Ω
Polarization	RHCP
Axial Ratio	≤3dB
Peak Gain	5.5dBi
LNA Gain	40dB (typical)
Noise Figure	≤1.8dB
Output/Input VSWR	≤2
Operation Voltage	3.3DC ~ 12V
Operation Current	≤50mA
Group Delay Ripple	≤5ns

MECHANICAL

Dimensions	Ø 150 x 61mm
Connector	TNC
Mounting	5/8" x 11 (British system)
Weight	450g

ENVIRONMENTAL

Operating Temperature	-40°C to 85°C (-40°F to 185°F)
Storage Temperature	-55°C to 85°C (-67°F to 185°F)
Humidity	95% non-condensing
Waterproof/Dustproof	IP67

CALIBRATION

NGS	Yes
IGS	No

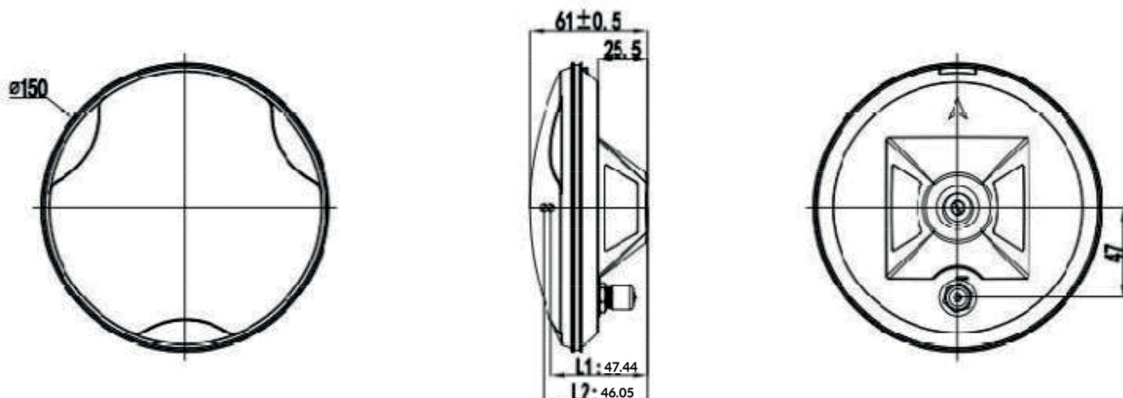

Illustrations, descriptions and technical specifications are not binding and may change

STONEX AUTHORIZED DEALER

STONEX®

Viale dell'Industria 53 - 20037 Paderno Dugnano (MI) - Italy
Phone +39 02 78619201
www.stonex.it | info@stonex.it